

# Hydrogen – A key enabler for the energy transition

Thijs Bouten, Jan Withag and Lars-Uno Axelsson  
OPRA Turbines International B.V.  
Hengelo, The Netherlands

Hydrogen is a clean and carbon-free fuel and is considered a key element for the energy transition. Renewable power generation by solar and wind is increasing, requiring flexible operation to balance the load on the energy grid with the ability to rapidly adjust the output. Gas turbines with a combustion system for hydrogen operation offers a low carbon solution to support the stability of the energy grid. This provides a solution capturing the needs for energy storage, in the form of hydrogen, and flexible power generation. Gas turbines are known to operate on a vast amount of different fuels and generally well-suited in fulfilling the wish for small-scale decentralized power generation. In gas turbine driven combined heat and power (CHP) applications a fuel utilization of above 90% can be achieved. These advantages fit well in the sustainability targets to reduce emissions and increase fuel efficiency. This paper will present an overview of the application of hydrogen for energy production in a gas turbine. This includes the various methods of hydrogen production, challenges of hydrogen and the application in various gas turbine combustor technologies. The paper will conclude with showcasing the current and future hydrogen capabilities of the OP16 gas turbine.

## 1 Introduction

Hydrogen is a clean and carbon-free fuel and is considered a key element for the energy transition. Renewable power generation by solar and wind is increasing [1, 2], requiring flexible operation to balance the load on the energy grid with the ability to rapidly adjust the output. Gas turbines with a combustion system for hydrogen operation offer a low carbon solution to support the stability of the energy grid. This provides a solution capturing the needs for energy storage, in the form of hydrogen, and flexible power generation.

Combustibles are still an important part of the energy chain. Small and medium enterprises that rely on heat and power on demand to control their processes, will seek for reliable solutions that are meeting the European targets. Gas turbines are in general well-suited to run on a large variety of fuels. The design makes it also possible to be fuel flexible and to run in different modes that can combine conventional and alternative fuels at the same time. Dual-fuel operation, bi-fuel operation or blending hydrogen with conventional or alternative fuels are possibilities to reduce the operational risk in the energy transition if hydrogen availability is not meeting the requirements. Together with the previous notes, gas turbines are known to efficiently operate on a vast amount of different fuels and generally well-suited in fulfilling the wish for small-scale decentralized power generation. Especially in combined heat and power (CHP) applications where a gas turbine can lead to an efficient system reaching heat utilization up to 90% of energy content of the fuel. These advantages fit well in the sustainability targets to reduce emissions and increase fuel efficiency.

A common way to produce hydrogen is through electrolysis of water, which decomposes the water into hydrogen and oxygen using electricity. When the electricity is generated by renewable sources, such as wind and solar, it is referred to as green hydrogen. By producing hydrogen using excessive renewable energy it can be used as a form of energy storage. Alternatively, hydrogen can be produced from natural gas, either as grey hydrogen whereby carbon dioxide is released to the atmosphere or as blue hydrogen whereby the carbon dioxide is captured and stored. More details regarding the production of hydrogen are discussed in chapter 2 of this paper.

The properties of hydrogen are significantly different from conventional fuels. The high flame speed, low density and small molecule size are challenging for operation. The challenges with respect to the properties of hydrogen are discussed in chapter 3. More details regarding the effect of hydrogen on gas turbine combustors are described in chapter 4. Finally, conclusions are drawn in chapter 5.

## 2 Production of hydrogen

Hydrogen is the most abundant chemical substance in the universe, on earth hydrogen exists in almost all organic compounds. Hydrogen as an energy carrier can be generated from a wide variety of fossil fuels and renewable energy. The most significant processes for hydrogen production will be discussed in this chapter. A distinction will be made between “Grey Hydrogen” and “Blue Hydrogen” which are made from fossil fuels and “Green Hydrogen” which is made from renewable sources.

### 2.1 Hydrogen production from fossil fuels (“Grey / Blue Hydrogen”)

Hydrogen can be produced by processing of various fossil fuels. Natural gas is currently considered to be the most important energy source for hydrogen production, at 70%, followed by oil, coal and electricity [3]. All of the processes described in this section produce carbon dioxide as a by-product of the hydrogen production. When the carbon dioxide is released into air, the hydrogen produced is named “grey hydrogen”. An overview of the various methods of grey hydrogen production is shown in Figure 1.

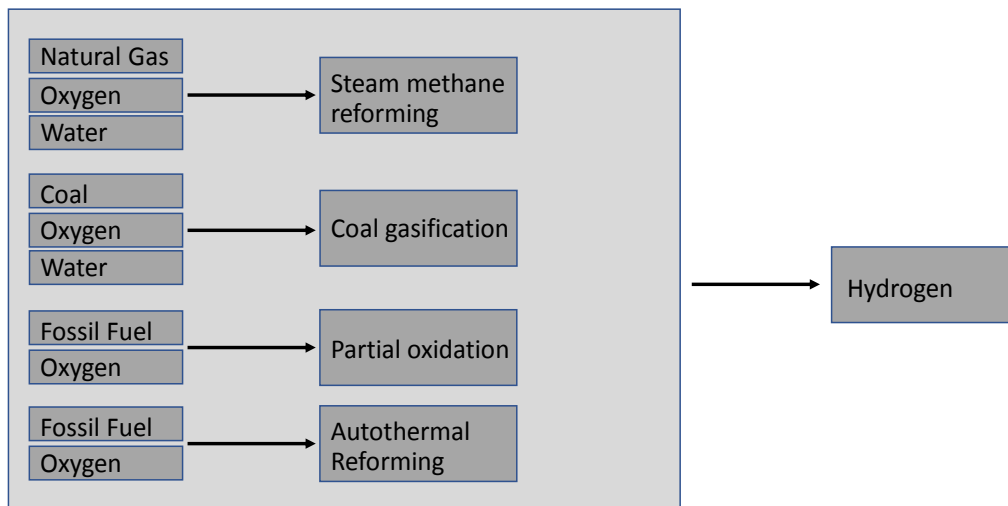

Figure 1: Grey Hydrogen production

When instead of releasing the CO<sub>2</sub> to the air, the CO<sub>2</sub> from this process is captured and stored the hydrogen produced is CO<sub>2</sub>-neutral. When the hydrogen is produced in combination with the Carbon Capture and Storage (CCS) process the hydrogen is called “blue hydrogen”. An overview of these processes is shown in Figure 2.

Steam methane reforming (SMR) is the primary method for hydrogen production. An endothermic reaction with steam and methane is used to produce a mixture consisting predominantly out of carbon monoxide and hydrogen, with small amounts of carbon dioxide and water vapour. Subsequently the carbon monoxide and the remaining water are converted to hydrogen and carbon dioxide by means of the water gas shift reaction.

A second process used for solid fossil fuels is gasification. When compared to SMR, gasification is a chemically more complex process which produces a higher ratio of hydrogen to carbon dioxide. Gasification is the reaction of a carbon carrier with an oxygen containing gas to form a synthesis gas containing both CO and H<sub>2</sub>. The water gas shift reaction is then used to convert the carbon monoxide and the remaining water into hydrogen and carbon dioxide.

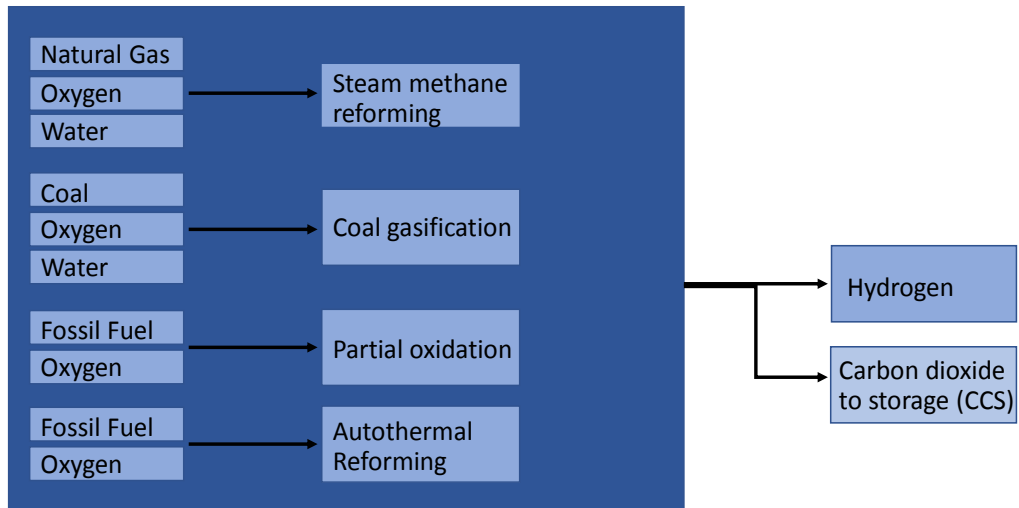

Figure 2: Blue Hydrogen production

Two processes which use partial combustion to drive the thermochemical reactions of the fossil fuel feedstock are Partial Oxidation and Autothermal reforming (ATR). These processes are for example used for the production of hydrogen from naphtha, LPG and heavy oils. When compared to SMR both of these processes have higher carbon dioxide emissions. Partial oxidation is an exothermic reaction that takes place at high temperatures and under high pressure forming a synthesis gas containing both hydrogen and carbon dioxide. The process of partial oxidation is less efficient than the process of steam methane reforming, but partial oxidation has the benefit that it is more flexible to types of raw material for the process.

ATR can be considered as a combination of partial oxidation and steam reforming. The required heat for the process is supplied by means of the partial oxidation and the steam reforming determines the hydrogen yield. Autothermal reforming is not dependent on an external heat supply, which is considered as an advantage, but there is limited commercial experience for the process.

## 2.2 Hydrogen production from renewable energy (“Green Hydrogen”)

At this moment, only small amounts of hydrogen are being produced from renewable energy, this amount is expected to significantly increase in the future. Renewable power generation by solar and wind is increasing (Figure 3), requiring flexible operation to balance the load on the energy grid with the ability to rapidly adjust the output. Conversion of the renewable energy into hydrogen is one of the methods to store the energy. When electricity from renewable energies becomes increasingly available it is expected that hydrogen produced from renewable energy will rise significantly. Even though hydrogen is gaseous and has a relative low energy density, it is considered to be the chemical with the highest potential for longer time scale electricity storage [4].

Hydrogen produced from renewable energy is called green hydrogen. An overview of the various production methods is shown in Figure 4. Hydrogen can be produced from renewable electricity by electrolysis, as discussed in section 2.2.1 or from biomass as described in section 2.2.2.

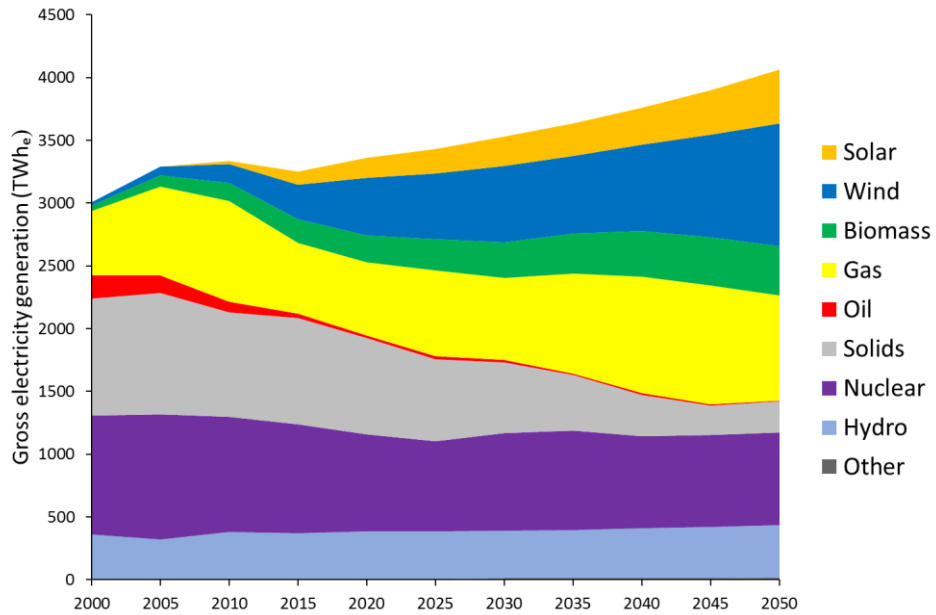

Figure 3: Historic and future gross electricity generation from various energy sources. Graph is based on EU Reference scenario 2016 [5]

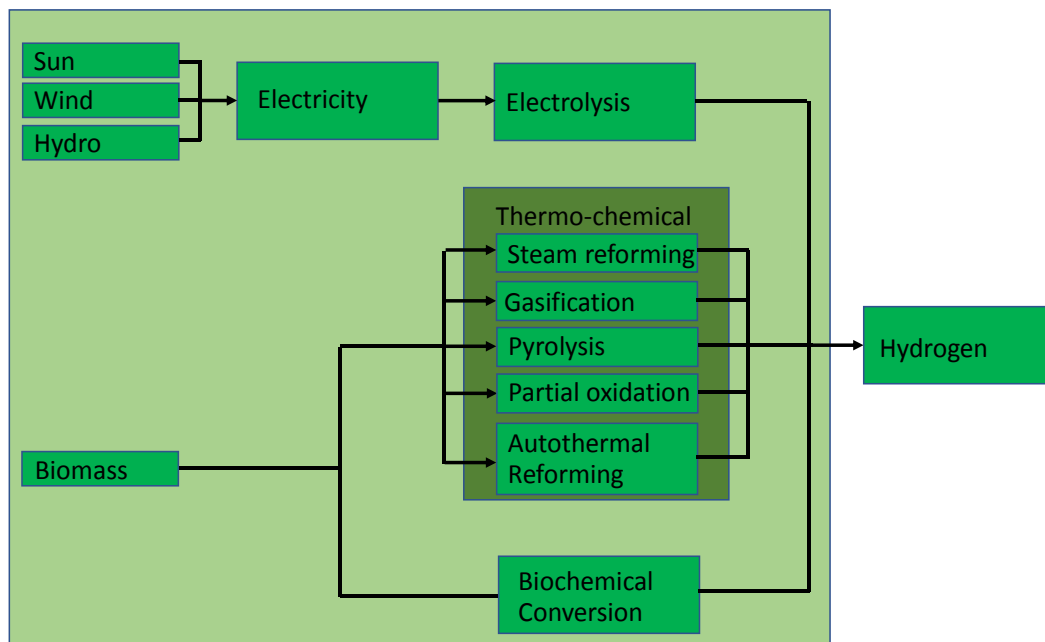

Figure 4: Green Hydrogen production

### 2.2.1 Electrolysis

Electricity from renewable sources such as wind or solar power can be used to drive the electrolysis of water. Electrolysis is a process by means of an electrolyser to break down water into hydrogen and oxygen. The electrolyser consists of a positive electrode (anode) and a negative electrode (cathode) separated by either an electrolyte or a membrane. The economic attractiveness of hydrogen production via electrolysis is very much dependent on electricity prices.

Three different types of electrolyser technologies are currently available as commercial products (Table 1), these are alkaline electrolysers, proton exchange membrane (PEM) electrolysers and anion exchange membrane (AEM) electrolysers. Dependent on the amount of electricity used to produce the hydrogen the efficiency can be determined. The efficiency of water electrolysers is currently between 60 to 80% [3], dependent on the method used.

**Table 1: Overview of commercially available electrolyser technologies [6].**

		Alkaline	PEM	AEM
Development status		Commercial	Commercial medium and small-scale applications	Commercial in limited applications
System size range	Nm <sup>3</sup> /hr kW	0.25 – 760 1.8 – 5,300	0.01 – 240 0.2 -1,150	0.1 -1 0.7 – 4.5
Hydrogen purity	%	99,5- 99,9998	99,9 – 99,9999	99,4
Indicative system cost	€/kW	1,000-1,200	1,900-2,300	N/A

The PEM electrolyser is of particular interest for gas turbines in combination with wind and solar power. This is because it can quickly be switched on and off, thus it can easily be adapted to the intermittent characteristics of the wind and solar power generation.

**2.2.2 Hydrogen from biomass**

Hydrogen from biomass is considered to be a low emission hydrogen production method since the CO<sub>2</sub> released was captured from the atmosphere in the first place. When carbon capture and storage is combined with hydrogen production from biomass this could even result in net negative CO<sub>2</sub> emissions.

The reforming processes described in Section 2.1 can also be used to produce hydrogen from biomass. In addition to these processes two additional processes will be described in this sub-section, these are pyrolysis and biochemical conversion.

Pyrolysis is the thermal decomposition of organic compounds at high temperatures in the absence of oxygen. When the pyrolysis is followed by a catalytic reformer it is possible to produce a mixture consisting out of methane, carbon monoxide, carbon dioxide and hydrogen.

Biochemical conversion of biomass into hydrogen can be achieved by means of microorganisms. The primary method of biochemical conversion of biomass is fermentation, this method produces a gas mixture containing hydrogen by anaerobically degradation of the biomass. The biochemical conversion route requires significant volumes of biomass, this could lead to restrictions for large-scale production.

### 3 Challenges of hydrogen

Hydrogen can be considered as an environmentally neutral substance as it is non-toxic and it is not causing any environmental damage. Under atmospheric conditions, hydrogen is an odourless, colourless and tasteless gas. However, the physical and chemical properties of hydrogen are fundamentally different than those from conventional fuel gas (Table 2).

**Table 2: Properties of hydrogen compared to other gases**

		Methane	Propane	Hydrogen
Density	kg/Nm <sup>3</sup>	0.678	1.882	0.085
Lower heating value	MJ/kg	50	49	120
Lower heating value	MJ/Nm <sup>3</sup>	33.9	92.2	10.2
Adiabatic flame temperature	K	2236	2527	2253
Laminar flame speed	m/s	0.38	0.42	1.70
Lower explosive limit [7]	vol%	5.0	2.1	4.0
Upper explosive limit [7]	vol%	15.0	9.5	75.0

#### 3.1 Flame speed

Hydrogen has a laminar flame speed of around five times higher than natural gas at similar conditions. Thus, flame flashback is one of the prime challenges in premixed hydrogen flames. Flame flashback is generally defined as upstream propagation of the flame due to an imbalance in local flame velocity and flow velocity. During a flashback event, the flame propagates upstream into the pre-mixer and changes the combustion type from the premixed to the diffusion type. This in turn increases the temperature and the pollutants of the flame and in parallel could lead to considerable damage to the equipment.

#### 3.2 Handling of hydrogen

Hydrogen has a significantly low energy density by volume compared to conventional fuel gases which could lead to large storage vessels for the hydrogen. To remedy this, one of these methods is used to store sufficient amount of hydrogen: high pressure storage, low temperature storage, absorption in materials or a combination of any of these. The table below shows the risk and safety issues related to the storage and transport of hydrogen.

**Table 3: Hydrogen storage and transport challenges [8]**

Material properties related issues	Hydrogen handling related issues
Impact on materials	Temperature variation
Liner blistering	Pressure fluctuation
Damage mechanisms of carbon fibres	Hydrogen leakage

Physical storage of hydrogen in enclosed containers can have detrimental effect on the storage material if proper material is not used. The impact of hydrogen on materials in the form of hydrogen embrittlement (HE) is of concern in steel storage systems. HE is responsible for crack growth in material, fracture initiation and catastrophic failure. Material selection should also consider hydrogen temperature and pressure fluctuations inside storage tanks which can result in shorter lifetime of the

equipment. Also, hydrogen molecules being light and small, can permeate through materials and seals relatively easily during storage and transport through pipelines. A leakage risk of three times that of natural gas was measured for hydrogen from leakage measurements.

## 4 Gas turbine combustion technology

Depending on the application, requirements and fuel available, a gas turbine is equipped with a specific type of combustor. Currently, three different combustion systems are available for the OPRA OP16 gas turbine. The 3A combustor (Figure 5) is a conventional, diffusion type, combustor capable of operating on a wide range of gaseous and liquid fuels. The 3B combustor (Figure 6) is a dry low-emissions (DLE) combustor specifically designed for low emission operation on natural gas. The 3C combustor (Figure 7) has been developed for operation on (ultra)-low calorific fuels including ethanol, pyrolysis oil, syngas, biogas, industrial waste gas and volatile organic compounds. The application of hydrogen in a gas turbine combustor affects the operability. This chapter discusses the implication for conventional combustor technology (section 4.1), DLE combustor technology (section 4.2), low calorific fuel combustors (section 4.3) and the next generation high hydrogen combustor (section 4.4).

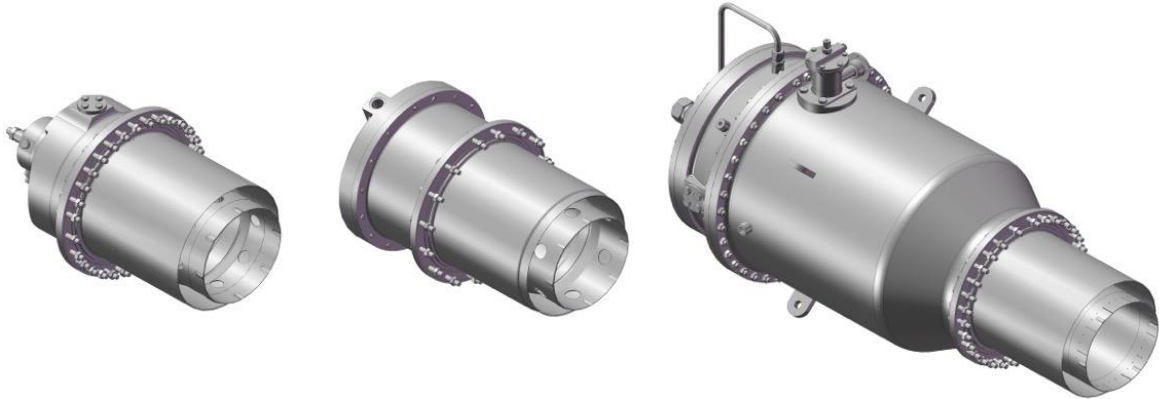

**Figure 5: 3A Conventional diffusion type combustor**

**Figure 6: 3B Dry low emission combustor**

**Figure 7: 3C Advanced diffusion type combustor for low calorific fuels**

### 4.1 Conventional combustor technology

Fuel and air are mixed in the flame in a conventional diffusion type combustor (for example the OPRA 3A combustor). The local high temperature in a diffusion flame results in an efficient conversion of the fuel. On the other hand, the high temperature enhances the formation of thermal  $\text{NO}_x$ . Conventional diffusion type combustors can handle a significant amount of hydrogen. OPRA successfully tested the 3A combustor with high amounts of hydrogen. The effect of hydrogen addition on the exhaust gas emissions is shown in Figure 8. Hydrogen addition increases the  $\text{NO}_x$  emissions, because of the increased local flame temperature. Next to flame temperature also the quality of mixing has impact on the  $\text{NO}_x$  emissions. The small hydrogen molecules mix better than larger hydrocarbon molecules. The initial drop in  $\text{NO}_x$  emissions for more hydrogen is caused by an improved mixing of the fuel with air. The  $\text{CO}$  emissions are decreased by hydrogen addition, this is an effect of the increased local flame temperature and the lower carbon contents of a hydrogen rich flame. The latter is also reflected in the  $\text{CO}_2$  emissions, which are reduced for an increased hydrogen content.

Water or steam injection can be used in conventional combustor technology to lower emissions at unattractive costs of demineralized water supply. Although conventional combustor technology can handle a high amount of hydrogen, it requires additional post-combustion treatment to meet the most stringent emission regulations.



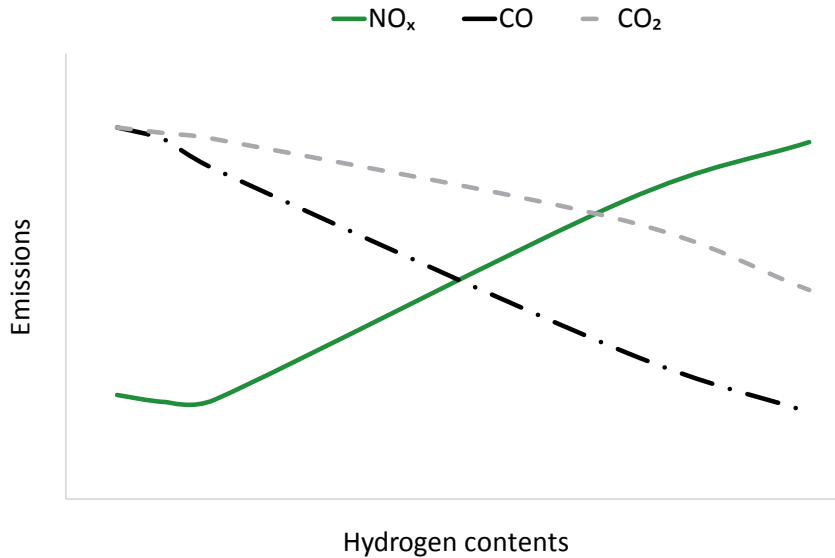

Figure 8: Trend of emissions in conventional combustor with increasing hydrogen contents

### 4.2 DLE combustor technology

Dry low emission (DLE) combustor technology (for example the OPRA 3B combustor) is based on premixed combustion. A premixed flame is characterized by the fact that the air and fuel are mixed before the combustion process takes place. The radial swirl stabilized DLE combustor of the OP16 is shown schematically in Figure 9. For reduction of pollutant emissions, especially NO<sub>x</sub> and CO, the low emission combustor is operating in premixed mode. The recirculation zone induced by the radial swirler stabilizes the highly turbulent flame. Regenerative impingement cooling is used to cool the combustion liner. Hereby the combustion air is cooling the liner, while increasing the air supply temperature to the primary zone. Main fuel is injected upstream of the swirler passages, premixing with air when passing through the high velocity swirler passages. The (partially) premixed gas mixture is injected into the primary zone of the combustor. Central pilot fuel supply is used for start-up and part load flame stabilization.

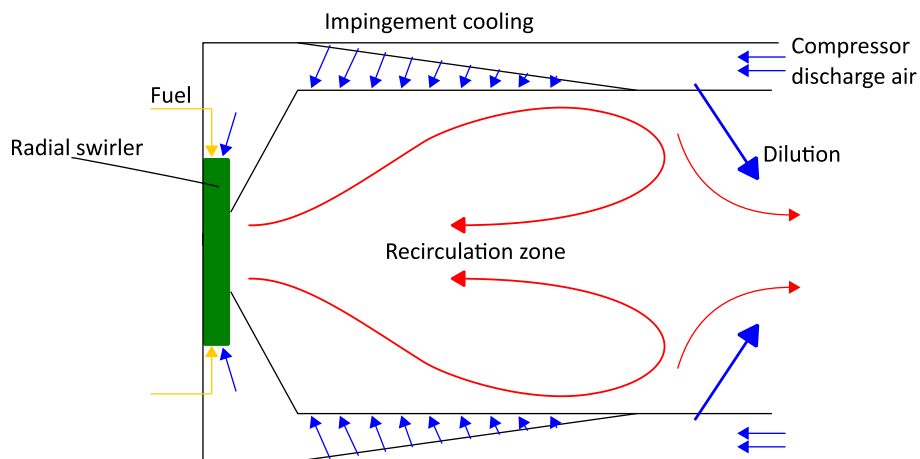

Figure 9: Schematic combustor aerodynamics of a DLE combustor

Conventional DLE technology can handle a limited amount of hydrogen because of the risk for flashback. Flame flashback is the upstream propagation of a flame due to an imbalance in flow velocity and local flame velocity. Due to the higher flame speed of hydrogen, flashback is one of the prime challenges in premixed hydrogen flames. During a flashback event, the flame propagates upstream up to the fuel injection. The combustion process changes thereby from premixed to diffusion type. This can cause severe hardware damage due to increased temperatures and undesirable flame stabilization locations.

### 4.3 Low calorific fuel combustor technology

Low calorific fuel combustor technology (for example the unique OPRA 3C combustor) is specifically designed for efficiently burning low calorific liquid and gas fuels [9, 10, 11]. The low LHV of the fuels result in completely different combustion properties compared to conventional (methane based) fuels. The volume of the combustor is significantly larger than for the conventional combustion systems. This ensures sufficient burnout time for carbon monoxide in syngas and carbon content in liquid fuels, such as pyrolysis oil. Some (ultra)-low calorific fuels will also contain a significant amount of dilutants. These dilutants will decrease the temperature of the flame, thereby slowing down the reaction rates.

If the energy carrying part of the fuel consists mainly of hydrogen and carbon monoxide, the fuel behaves different than methane-based fuels. This is for example the case for syngas where the carbon monoxide part requires a long reaction time and hydrogen reacts fast. Low calorific fuels with high hydrogen contents can be burned efficiently with low emissions. OPRA successfully tested the 3C combustor on low calorific syngases with a hydrogen level up to 50% by volume [11].

### 4.4 Next generation high hydrogen combustion technology

In the strive for reliable power generation with low carbon footprint (e.g. European Commission 2050 Energy Strategy Directives [2]), carbon-free hydrogen value chains will play an important role. Therefore, OPRA is working on the development of the next generation hydrogen combustion technology. The objective is to develop a cost-effective, ultra-low emission combustion system that is capable of burning hydrogen. A key requirement is fuel flexibility and stable operation from 100% natural gas to 100% hydrogen and any mixture thereof. This is a key challenge as extreme changes in fuel reactivity switching from natural gas to hydrogen can result in dramatic shifting of heat release within the combustor, which can be physically destructive if not well controlled. With the development of the fuel-flexible and ultra-low emission hydrogen combustor, the OP16 gas turbine is and will remain a key solution in the future decentralized energy landscape.

## 5 Conclusions

Hydrogen as an energy carrier can be generated from a wide variety of fossil fuels and renewable energy. The amount of hydrogen produced using renewable energy is expected to significantly increase in the future. Renewable power generation by solar and wind is increasing, requiring flexible operation to balance the load on the electricity grid with the ability to rapidly adjust the output. Conversion of the renewable energy into hydrogen is one of the promising methods to store the energy. When electricity from renewable energy becomes increasingly available it is expected that hydrogen produced from renewable energy will rise significantly.

Hydrogen can be considered as an environmentally neutral substance as it is non-toxic, and it is not causing any environmental damage. Under atmospheric conditions, hydrogen is an odourless, colourless and tasteless gas. However, the physical and chemical properties of hydrogen are fundamentally different than those from conventional fuel gas. Hydrogen has a laminar flame speed of around five times that of natural gas at similar conditions. Thus, flame flashback is one of the prime challenges in premixed hydrogen flames. Another large challenge arises with the handling of hydrogen due to the low energy density, possibility of hydrogen embrittlement and the high permeability of hydrogen.

The application of hydrogen in a gas turbine combustor affects the operability. A key requirement for hydrogen is fuel flexibility and stable operation from 100% natural gas to 100% hydrogen and any mixture thereof. This is a key challenge as extreme changes in fuel reactivity switching from natural gas to hydrogen can result in dramatic shifting of heat release within the combustor, which can be physically destructive if not well controlled. Already at this moment, OPRA's OP16 gas turbine combustors can handle a high amount of hydrogen. However, to meet the future requirements OPRA

is working on the development of the next generation hydrogen combustion technology. The objective is to develop a cost-effective, ultra-low emission combustion system for that can operate on 100% natural gas and 100% hydrogen, and any mix thereof. With the development of the fuel-flexible and ultra-low emission hydrogen combustor, the OP16 gas turbine is and will remain a key solution in the future decentralized energy landscape.

## 6 References

- [1] European Commission, “Renewables: Europe on track to reach its 20% target by 2020,” European Commission, Brussels, 2017.
- [2] European Commission, “Energy Roadmap 2050,” European Commission, Brussels, 2011.
- [3] J. Adolf, C. H. Balzer, J. Louis, U. Schabla, M. Fishedick, K. Arnold, A. Pastowski and D. Schüwer, “Energy of the future? : Sustainable mobility through fuel cells and H2 ; Shell hydrogen study,” Shell Deutschland Oil, Hamburg, 2017.
- [4] M. Bos, “Storage of renewable electricity in methanol,” University of Twente, Enschede, 2019.
- [5] European Commission, “EU Reference Scenario 2016; Energy, transport and GHG emissions; Trends to 2050,” 15 July 2016. [Online]. Available: <https://ec.europa.eu/energy/en/content/reference-scenario>.
- [6] E4tech, “Study on the development of water electrolysis in the EU,” Lausanne / London, 2014.
- [7] Matheson gas, “Lower and Upper Explosive Limits for Flammable Gases and Vapors (LEL/UEL),” [Online]. Available: [https://www.mathesongas.com/pdfs/products/Lower-\(LEL\)-&-Upper-\(UEL\)-Explosive-Limits-.pdf](https://www.mathesongas.com/pdfs/products/Lower-(LEL)-&-Upper-(UEL)-Explosive-Limits-.pdf). [Accessed 21 October 2016].
- [8] R. Moradi and K. Groth, “Hydrogen storage and delivery: Review of the state of the art technologies and risk and reliability analysis.,” *International Journal of Hydrogen Energy*, vol. 44, no. 23, p. 12254 – 12269, 2019.
- [9] M. Beran and L.-U. Axelsson, “Low calorific fuel combustor for gas turbine”. United States Patent 9625153 B2, 18 April 2017.
- [10] M. Beran and L.-U. Axelsson, “Development and Experimental Investigation of a Tubular Combustor for Pyrolysis Oil Burning,” *Journal of Engineering for Gas Turbines and Power*, vol. 137, no. 3, p. 031508, 2015.
- [11] T. Bouten, M. Beran and L.-U. Axelsson, “Experimental Investigation of Fuel Composition Effects on Syngas Combustion,” in *Proceedings of ASME Turbo Expo 2015*, Montréal, 2015.